

FIRMA®

MARCH 2023

Cavity Tray Technical

Non-combustible stainless steel cavity tray systems designed to meet Class A1 Rating in compliance with Document B, permitted for Buildings over 18m in height. Available as a complete building solution or as individual components.



Our Product



Scan QR Code to view full product range on our website!

CAVITY TRAY CREDENTIALS

- > Fully **A1 rated** to comply with the Approved Document B 2019 amendments
- > Designed with a **thermal break isolator** to prevent cold bridging in the **cavity wall**
- > Full design and scheduling service included as standard. Product **cut and manufactured** to schedule to facilitate fast site installation
- > Unique **mottled design** on the base of the cavity tray to provide greater adhesion to the **stainless tray**
- > Corner joints and details are all **pre-fabricated** to suit the schedule and prior to delivery on site.
- > Available on 3-4-week lead times, subject to a review of project requirements

BA Systems design, manufacture and supply stainless steel **non-combustible cavity tray** which satisfies the requirements of the **current ban on combustible materials** used on residential buildings over 18m in height. All stainless-steel cavity trays are manufactured in house with the extensive BA laser cutting and sheet metal working equipment.

2.

Call 01603 722330 web www.firma.co.uk email info@firma.co.uk



Cavity Tray Components

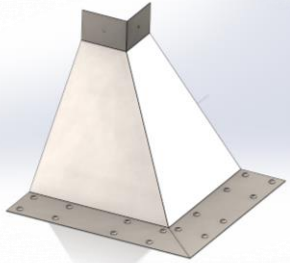

1

External Corners

External Corners are fully fabricated stainless-steel corners which are installed as starting points for the whole cavity tray system.

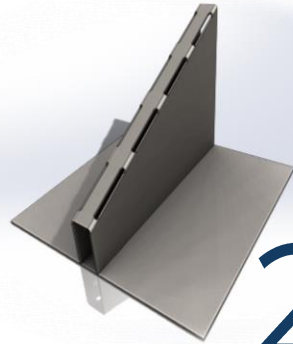

2

Weep Vents

Weep Vents are fully fabricated non-combustible vents which need to be incorporated into the design. Weep vents should be placed 225mm from the inside of the stop ends and at 450mm centers thereafter.

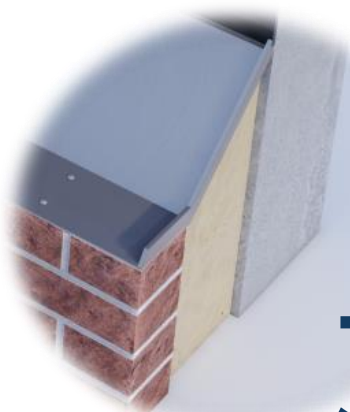

3

Stop Ends

Stop Ends provide a watertight seal above door or window openings and ends of cavity tray runs.

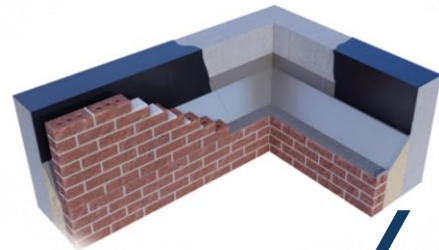

4

Bespoke Corners and Joints

Bespoke Corners can be designed and prefabricated for special applications.

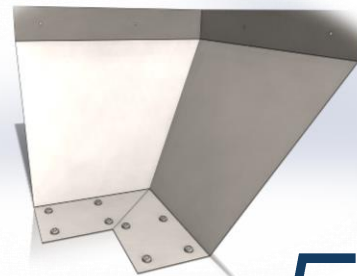

5

Internal Corners

Internal Corners are fully fabricated stainless-steel corners which are installed as starting points for the whole cavity tray system.

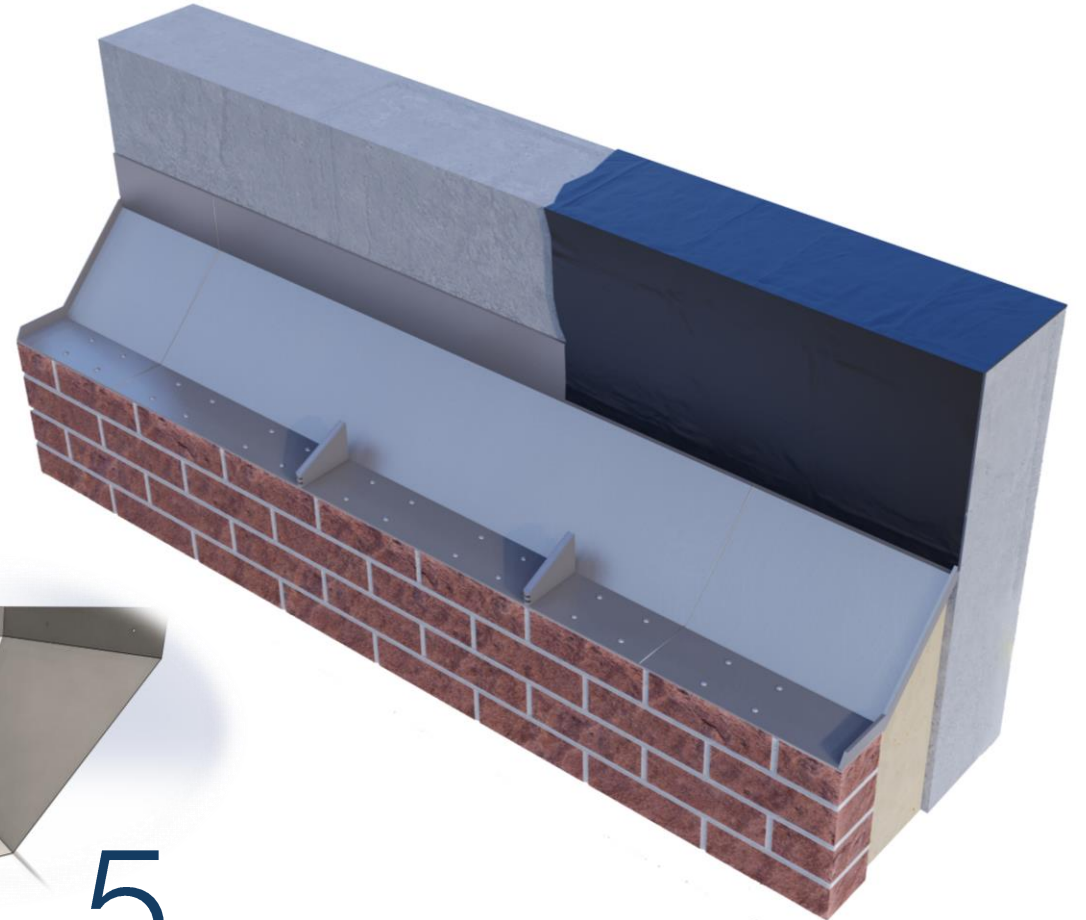

Cavity Tray Technical Details

1) Technical Data

- Cavity trays are to be installed with the external face flush with the face of the brickwork.
- Cavity trays are to be fixed to the internal sheathing board. The DriMax cavity tray has pre drilled holes for fixing and should be fixed with the thermal spacer and stainless-steel screws.
- The breather membrane or waterproofing membrane is then dressed over this.
- A 5mm bed of mortar should be laid and the cavity tray is embedded into this.
- The cavity tray should be installed as close vertically as possible to the opening it is protecting but no more than 225mm above.
- The DriMax weep vents are to be designed and installed within a maximum of 225mm from the end of the tray and at 450mm spacings thereafter.
- DriMax sealing tape is to be used with the DriMax Stainless Steel Cavity Trays.
- The standard product is manufactured from grade 1.4301, commonly known as grade 304.
- The trays can also be manufactured from grade 1.4401 (Grade 316) for buildings that are located close to the sea or where the environment is more aggressive or corrosive.

2) Setting Out Details

- Internal and external corners should be first laid out and carefully positioned.
- Double sided tape at the rear of the cavity tray corners should be exposed and pressed up against the fibre board or sheathing board of the inner wall of the building.
- Pre drilled holes in the fixing edge should be used to screw the corners into the sheathing board with stainless steel screws.
- Once the corners are secured the lengths between corners can be laid out.
- Lengths of cavity tray material are supplied in maximum length of 2400mm and these should be laid out with a minimum overlap of 150mm.
- The double sided butyl tape is used to secure the hidden joint of the cavity tray ends and the exposed ends should be sealed with single sided butyl tape.
- Lengths of cavity tray can easily be cut for closing pieces with a 4.5-inch grinder and a 1mm abrasive blade, using the appropriate safety protection.
- Weep joints should be fitted at the brick joints at maximum spacings of 450mm.
- The weep joints have double sided butyl tape for placing in position on the cavity tray.

Cavity Tray Design

4) Design

- The DriMax cavity trays are fabricated from stainless steel which satisfies the requirement for an A1 classification without testing according to document 96/603/EC. This standard clearly states that the material would be considered as non-combustible.
- BA Systems have an in-house design team able to develop profiles for specific cavities widths from 30mm up. The trays can be designed to suit specific requirements on reveals and ends. Overall lengths can also be designed to allow for minimal on-site wastage.

Typical Weep Vent

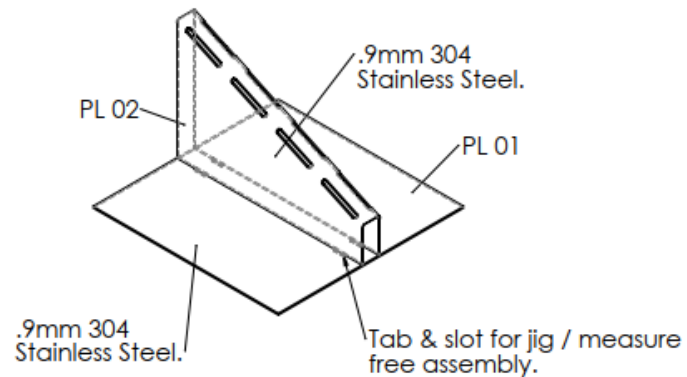

Typical Profile Section

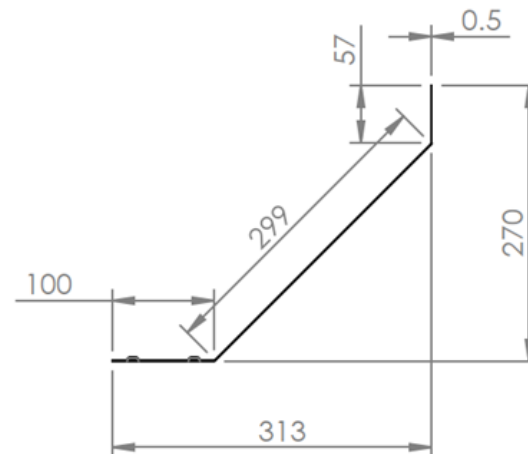

2400mm length Cavity

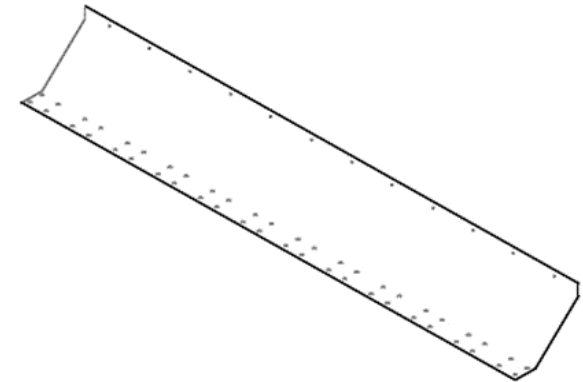

Specification

| Product Name | DriMax Cavity Trays |
|--------------------|----------------------------------------------------------|
| Maximum Length | 2400mm |
| Width | Produced to Specific requirements |
| Material | Grade 304 Stainless Steel |
| Material Thickness | 0.5mm and 1.5mm for the corners and ends and weep joints |
| Overlap of Lengths | 150mm |
| Fixings | Stainless Steel Tek Screws |
| Corner Angles | 90 degrees. Bespoke corners can be formed as required |

Get in touch

For product information,
or to discuss your project
please **get in touch today:**

Call +44 (0) 1603 722 330

Email info@firma.co.uk

