

Althon

Surface Water Management and Flood Prevention

Precast Concrete Headwalls

Sewers for Adoption

Environment Agency

Severn Trent

Precast Outfalls

Swale Inlets

Box Culvert Headwalls

Angled Headwalls

Trash Screens

Outfall Safety Grilles

Manhole Safety Chains

HDPE Flap Valves

Wall Mounted

Pipe Mounted

Flange Mounted

Cast Iron Flap Valves

HDPE Penstocks

Inline Penstocks

Hand Stop Gates

Stop Logs

Orifice Plates

WaStop Valves

Tideflex Valves

Penstock Chambers

Precast Chambers

Concrete Drainage Channel

Slot Drainage Channel

Polymer Drainage Channel

Steel Drainage Channel



www.althon.co.uk

Althon Ltd

Althon, originally called Allpipe was incorporated in 1981.

Allpipe was established to sell and hire site equipment such as pipe testing stoppers, manhole shutters and safety equipment.

In 1986 Allpipe began selling a concrete 'V' channel system with a concrete lid to drain large paved areas, motorway service areas, supermarket car parks, retail parks and the like. The surface water run-off from these areas had to be drained from the surface very quickly, stored and then discharged into the drainage system at a rate that wouldn't overload the system.

Althon first started selling headwalls in 2004 initially to the agricultural market then to large road and rail infrastructure projects.

In 2007 Allpipe changed its name to Althon as the company was best known for its Althon high capacity channel drain system. In 2011 the Allpipe name was re-established to take on the pipe testing stoppers, manhole shutters and safety equipment sales and hire business allowing the Althon business to concentrate on high capacity drainage channel and headwalls.

Althon continued to expand their product range to include products associated with their headwall range, outfall gratings, flap valves, penstocks and hand railing. These products were available as standalone products but the market also wanted them fitted to headwalls at the factory so they could be delivered to site complete.

The Pitt Review 'Lessons learned from the 2007 floods' published in 2008 brought the problem of surface water run off back to the forefront of everyone's mind and highlighted the need for a solution to the speed and quantity of run-off from hard landscaped areas. It was no longer seen as just a problem for large surfaced areas but also housing developments that needed to be solved locally rather than passing it downstream.

Many water authorities weren't keen to adopt hard engineered solutions so they looked at soft engineered options such as ponds, detention basins and swales, each of these would need an inlet and outlet structure and where these were to be adopted they would need to comply with the latest edition of the 'Sewers for Adoption' Guidelines.

2012 saw the introduction of the Althon range of SFA headwalls.

'Headwalls are our business so we take them seriously, supplying the right product for your job is our priority'

Index

| | |
|---------------------------|----|
| Standard Headwalls | 4 |
| SFA Headwalls | 5 |
| RSFA Headwalls | 6 |
| Other Headwalls | 7 |
| Headwall Accessories | 8 |
| Trash Screen and Gratings | 9 |
| Flap Valves | 10 |
| WaStops and Tideflex | 11 |
| Penstocks | 12 |
| Penstock Chambers | 13 |
| Drainage Channels | 14 |

Standard Headwalls

Althon manufacture and supply the most comprehensive range of headwalls in the United Kingdom.

- ✓ **Fast, easy and safe to install**
- ✓ **No on-site formwork or shuttering required**
- ✓ **Can be manufactured to accommodate multiple pipe openings**
- ✓ **We can supply a range of outfall safety grilles and trash screens factory fitted**
- ✓ **Pipe invert level and opening can be cast to site specific requirements**

All our headwalls are designed to BS EN 1992-1-1:2004 (EC2) and manufactured to BS EN 15258:2008 and BS EN 13369:2013 and carry the CE Mark.

All our headwall grilles are manufactured to IAW EN 1090-2:2018 EXC Class 1 with galvanising carried out after fabrication to BS EN ISO 1461:2009 and carry the CE Mark. Headwalls are our business so we take them seriously. Supplying the right product for your job is our priority!

The size of the pipe being used isn't the only thing that dictates which headwall should be used.

The depth of cover above the pipe where it meets the headwall and the height above the apron of the invert of the pipe will dictate the overall height of the back wall. The slope of the bank will dictate the wing wall profile and the size of any accessories that need to be fitted, such as flap valves, gratings, weir walls or baffle blocks will dictate the width of the back wall and the length of the apron.

Different adopting authorities have different requirements, such as invert level of the pipe above the apron, type of grating, access requirements, safety guidelines etc. Althon cater for all these.

When manufacturing we can cast in threaded sockets to aid the fixing of accessories such as gratings, flap valves, penstocks, access ladder, stop-logs and Kee Klamp handrail and where possible the headwalls are delivered to site fully assembled helping to achieve a safe and timely installation.



SFA Headwalls

Althon 'SFA' headwalls are specifically designed to meet the 'Sewers for Adoption' guidelines.

- ✓ **Designed to fully comply with Sewers for Adoption guidelines**
- ✓ **No specialist lifting equipment required**
- ✓ **Designed & manufactured to BS EN 15258 & BS EN 13369**
- ✓ **Can be manufactured to accommodate multiple pipe openings**
- ✓ **Fast, easy and safe to install**
- ✓ **No on-site formwork or shuttering required**
- ✓ **We supply a range of outfall safety grilles and trash screens factory fitted**
- ✓ **Various toe depths and thicknesses available**

It's not just the depth and thickness of the toe that makes a headwall SFA compliant. Sewers for Adoption guidelines call for the toe to be 500mm thick and extend a minimum of 600mm below the hard bed level of the watercourse. The size of the outfall safety grille dictates the width of the back wall required & the wing wall profile should follow the bank as closely as possible.

Our basin inlet headwalls have a 50mm fall in the apron from back to front, a minimum of four back wall heights, wing wall profiles and a choice of toe thicknesses and depths.

Our basin outlet headwalls have a flat apron, a minimum of four back wall heights, wing wall profiles and a range of toe thicknesses and depths.



We are able to cast onto the apron of the basin inlet headwalls stepped baffle blocks for when the velocity of the discharge needs to be dissipated before it enters the watercourse.

Onto the apron of the basin outlet headwalls we can cast a water cushion across the front to construct a silt trap before the surface water enters the pipe system.

In most cases where the fall height is in excess of 600mm some form of barrier is required, we can fit genuine Kee Klamp handrails to the headwall in various configurations with mesh infill if necessary.

Where access to the apron is required galvanised mild steel ladders or precast concrete steps can be included.



RSFA Headwalls

- ✓ **Designed specifically to meet Severn Trent Water requirements**

- ✓ **Fast, easy and safe to install**

- ✓ **No specialist lifting equipment required**

- ✓ **Designed & manufactured to BS EN 15258 & BS EN 13369**

- ✓ **We can supply a range of outfall safety grilles and trash screens factory fitted**

- ✓ **Genuine Kee Klamp handrails can be factory fitted**

- ✓ **Various toe depths and thicknesses available**

Our RSFA range of headwalls were designed to meet the very specific requirements of Severn Trent Water.

Severn Trent Water have specific details for each type of headwall requirement based on height of back wall, access requirements, baffle blocks, gratings, flap valves, the spacing of these accessories and wing wall profiles. The RSFA range of headwalls includes the option to discharge at a 30 degree angle to the watercourse.

RSFA11 & RSFA12 Headwalls
comply with STD6001

RSFA18A, RSFA18B &
RSFA20B Headwalls
comply with STD6002

RSFA21B Headwalls
comply with STD6003

All our Sewers for Adoption
Outfall Safety Grilles
comply with STD6006

Other Headwalls

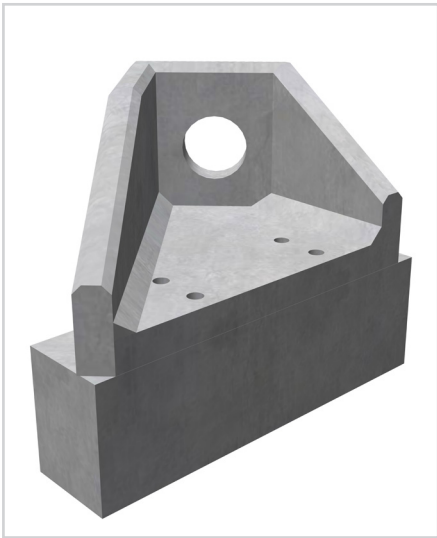

Angled Headwalls

Angled precast headwalls allow pipework entering a watercourse at an angle to be accommodated or for an outfall to be situated on a bend in a river. Discharging to a watercourse at 45 degrees to the flow is the Environment Agency's preferred option. The AH4C precast headwalls meet the Environment Agency's 'Standard rules SR2015 No 27 – Constructing an outfall pipe of 300mm diameter through a headwall into a main river' and exempt flood risk activities: environmental permits section FRA12 'Outfall pipes less than 300mm diameter through a headwall'.



Headwalls for Box Culvert

Althon manufacture a range of headwalls suitable for use with box culverts and ovoid pipes. Openings in the headwalls are cast to mirror the internal profile of the box culvert or ovoid pipe and all the normal accessories can be factory fitted if required. We are also able to provide mammal shelf/ledges on the wing walls to continue on from the box culvert if required.



Swale Inlet Headwalls

Althon swale and pond inlet mitred headwalls up to 300mm are fibre reinforced precast concrete open inlets allowing surface water runoff to enter SUDS features, or to act as an outlet or overflow. The profile of the inlet 1:3 (18 degrees) is the same as the surrounding ground in accordance with guidelines for the construction and adoption of swales and ponds. There is a recess formed in either side to key the unit into the slope of the swale or pond and prevent it slipping. We can provide our swale and pond inlets with stainless steel, galvanised steel bar or mesh gratings. The grilles are fixed to the inlet with four anti-tamper bolts, when the bottom two bolts are removed the grating hinges for ease of maintenance. The grating is located in an 8mm deep recess in the face of the unit to protect it from damage during routine maintenance such as mowing.

Headwall Accessories

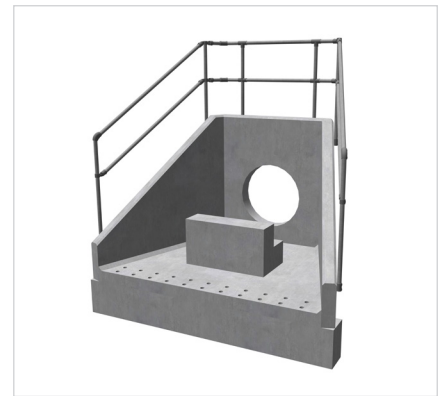

Flap Valves, Penstocks and Tideflex Duckbill Valves

As well as supplying flap valves, penstocks, tideflex duckbill valves and Kee Klamp handrail (amongst other accessories) as standalone items we can also factory fit them to our headwalls and chambers. During manufacture we cast in threaded sockets for the accessories allowing for easy fitting without the need for any drilling or resin fixing. The accessories are fitted at the factory to ensure they fit and wherever possible delivered to site fitted, if they can't be delivered assembled due to height or lifting access it's a simple case of bolting on.

Cascade Panels

Where a headwall is situated away from the waters edge, for instance on the bank of a pond where there is not normally a great depth of water, we can supply a precast concrete cascade panel which is the same width as the front of the headwall and extends the spillway as required. We can also produce these so an angled discharge is possible. Where necessary we can provide the cascade panels with dissipation blocks cast on.

Dissipation & Baffle Blocks

Where necessary we can cast onto the apron of the headwall dissipation or baffle blocks to slow down the discharge from the outlet therefore preventing turbulence and subsequently erosion. The baffle blocks vary in size from 75 x 75 x 75mm up to 400 x 400 x 400mm or a stepped version is available, the width depends on the pipe diameter and can consist of steps up to 500 x 500mm. The dissipation blocks are normally 230 (190) x 105 (65) x 59mm and tend to be used on the smaller headwalls.

Trash Screens & Gratings

Fitting a screen or grille to a headwall structure is normally down to two things, safety and security to prevent unauthorised access or to prevent debris entering the culvert.

A screen is a potential factor in a blockage occurring so the Environment Agency recommend that a screen is only fitted once a full evaluation of the need for a screen has been carried out.

We produce a range of trash screens to fit our headwalls together with bespoke units to fit existing or new built brick and in-situ structures. Trash screens can be cranked, sloped or cage type with bar spacing to suit the type of debris likely to be encountered. Multi-stage screens with working platforms, access doors, ladders and handrail can also be fabricated to order.

Safety and security grilles are normally required on openings over 350mm dia. and are fitted where there's a likelihood of unauthorised access to the culvert. The spacing of the bars is normally no more than 140mm.

Sewers for Adoption guidelines call for an outfall safety grille to be fitted on all openings over 350mm, it's a specific type of grating, hinged with padlock facility and has to be overall 270mm wider than the outside diameter of the pipe being used. Some water companies have their own versions and we offer these along with other variations to the original design, for instance, twin hinged where room is an issue, with free flow opening at bottom of grille or circular where there isn't a headwall to fit them to.

All of our trash screens and security/safety grilles are available in galvanised mild steel or stainless steel & carry the CE Mark.

- ✓ **Supplied with all necessary fixings**

- ✓ **Can be factory fitted to headwalls, standard and bespoke options available**

- ✓ **Where applicable can be manufactured to Environment Agency Trash & Security Screen Guide 2009**

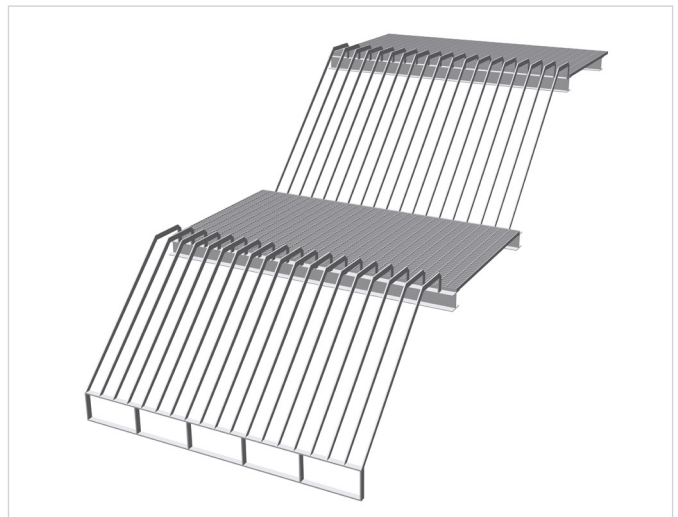

Flap Valves



- ✓ **No corrosion**

- ✓ **Low density and lightweight**

- ✓ **Impact resistance**

- ✓ **Good chemical resistance**

- ✓ **High UV protection**

- ✓ **Fish friendly options available**

- ✓ **Flexibility in design**

- ✓ **Very low opening pressures**

- ✓ **Low head losses**

We have a range of flap valves available as standard from 100mm to 2000mm Dia. and 150 x 150mm to 2000 x 2000mm square. Larger sizes can be designed and manufactured to order.

These valves come with wall, pipe or Flange mounting options and as standard are designed to resist a permanent water pressure (50 years) of 1 metre water column from the top of the opening and 5 metres water column from the bottom of the opening for only a short duration (up to 72 hours).

We provide a checklist that takes numerous factors into account to help establish which flap valve best suits the application:

- *Permanently submerged or flood prevention / emergency?*

- *Gravitational flow or pressure pipes?*

- *Different mounting options?*

WaStops & Tideflex

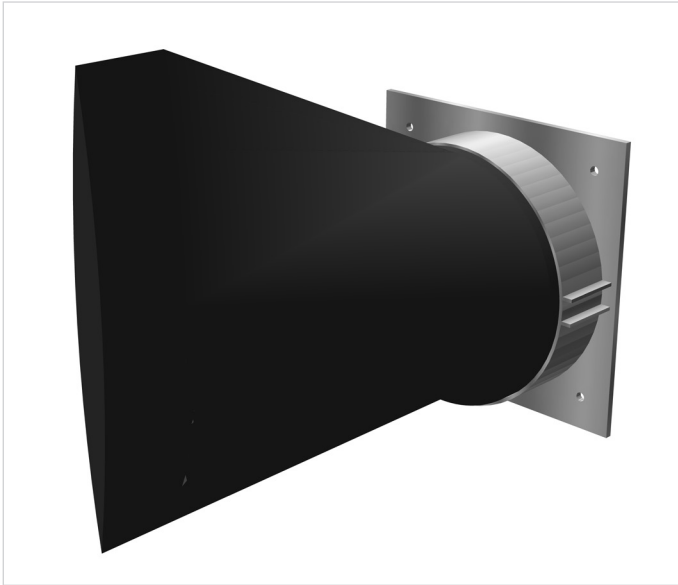

WaStop

- ✓ Virtually no maintenance
- ✓ Versatile mounting methods
- ✓ Easy to install

WaStop valves are inline backflow and flood prevention valves. WaStop inline non return valves (NRV) are made up of either a stainless steel grade 304 or 316 incorporating a cone-shaped chloroprene membrane. The membrane allows flow to pass in the desired direction but when backflow occurs the membrane fills out and seals the pipe. The WaStop is available in a number of standard sizes suitable for up to 8MwC. Special sizes and pressures are available on request.

Tideflex Traditional Duckbill Valve

- ✓ Low headloss maximises flow
- ✓ 25+ year design life
- ✓ Self-clearing of debris so eliminates potential blockages

Tideflex non-return valves are the original duckbill valves consisting of a one-piece rubber matrix of numerous natural and synthetic elastomers and ply reinforcement. These elastomeric check valves operate on differential pressure, using line pressure and back pressure to open and close, so no outside energy source is required. Can be supplied either as Flange mounted, Backplate mounting or slip-on with stainless steel clamp.

CheckMate UltraFlex

- ✓ Low cracking pressure
- ✓ Located inside the pipe
- ✓ Easy to fit

The CheckMate UltraFlex inline non-return valve has a 100% fabric and elastomer construction that eliminates corrosion problems and provides a proven record of maintenance free backflow prevention. The CheckMate UltraFlex inline non- return valve offers the lowest headloss in the Tideflex range.

Penstocks

Our wall & channel mounted penstocks are available in sizes up to 2000mm Dia. or 2000mm square as standard with larger sizes designed and manufactured to order.

- ✓ No corrosion
- ✓ 50 year design life
- ✓ Low density and lightweight
- ✓ Impact resistance
- ✓ Good chemical resistance
- ✓ High UV protection
- ✓ Can be combined with flap valve flexibility in design

As standard they meet pressures of up to 5 metre water column both on and off-seating. Our penstocks can also be supplied to withstand greater water pressures and with a flush invert if required.

As well as the standard wall mounted version our penstocks are also available as Weir Penstocks where there is a limited installation height and a Pipe Mounted version for Flange or Pipe Socket mounting.

We can also supply overflow penstocks to regulate water levels to determine which product is suitable for which situation the following have to be taken into consideration:



- *Flow direction – is the pressure from the front or back, or both?*
- *What is the maximum water pressure in meter water column?*
- *Is it wall, channel or pipe mounted?*
- *Operational functions such as local or remote operation / rising or non-rising spindle?*

We also have available a simple Hand Stop valve to be used in end of line applications with small dimensions and low pressures.

Penstock Chambers



Althon penstock chambers are manufactured to BS EN 15258:2008 & BS EN 13369:2013 and carry the CE Mark.

- ✓ **Fast, easy and safe to install**
- ✓ **No onsite drilling required**
- ✓ **No on-site formwork or shuttering required**
- ✓ **Can be manufactured to accommodate multiple pipe openings**
- ✓ **Designed & manufactured to BS EN 15258 & BS EN 13369**

Our penstock chambers have been designed to ensure installation on site is as swift and safe as possible. We cast fixing points for the penstocks into the chamber walls meaning the unit does not have to be drilled on site.

We will cast the pipe opening into the chamber wall to suit the specified pipe diameter at the required invert level.

Althon are able to supply penstock chambers with actuators inside the chamber or for operation remote from the chamber. We are also able to supply our precast chambers fitted with other accessories such as flap valves and Tideflex duckbill valves.

As standard we will provide a precast cover slab with 600 x 600mm opening. This opening can be customised to suit your specific requirements. Alternatively, we can provide a mesh catwalk with access hatch or assist with the design of alternatives. We also provide step irons or ladders where required.

Drainage Channels

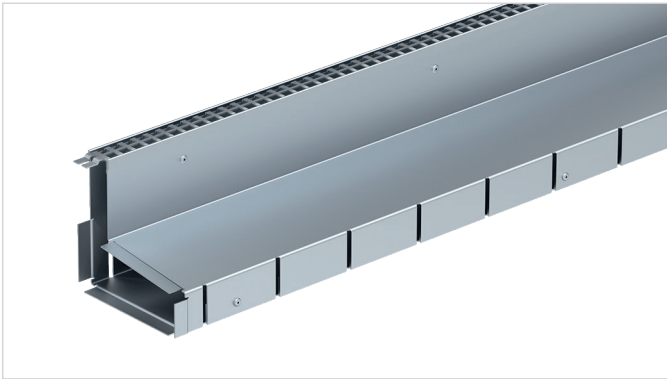

Stainless Steel Slot Drain

Althon slot drains are available in galvanised or stainless steel. Althon slim slot drains are a discreet method of draining hardstanding or landscaped areas.



Concrete Slot Drainage Channel

Althon concrete slot drainage channels are suitable for use on large scale industrial developments, airports, ports and container terminals as well as motorways. Our concrete slot drainage channels Profile I-1 through to III-1 are available in F900 load classes. Our slot drainage has kerb options within the range and is supplied in 4 metre lengths. Our 4 metre long standard channel sections allow for fast installation once on site.



Heavy Duty Drainage Channel

Althon BGZ-S concrete drainage channel range is a concrete drainage channel system available in widths from 100mm up to 500mm. Our concrete drainage channel has exceptional load bearing capabilities. Althon BGZ-S concrete drainage channel has been developed for areas where massive acceleration or braking forces and torque could occur. Our concrete channel drain system is available with gratings up to load class F900. Mesh, slotted and solid gratings and covers are available.



Shallow Concrete Drainage Channel

Althon shallow concrete drainage channels are available with cast iron or galvanised steel edges and have an innovative quick-locking system for easy installation. There are four lugs on the lower side of the grates which make sure that the system is not vulnerable to longitudinal displacement. If required the gratings can also be bolted in place. Our shallow concrete drainage channels are available with cast iron or galvanised gratings which can be slotted or mesh. Shallow concrete drainage channels are available from 100mm - 300mm wide internally and can be used in applications up to E600 load class where only shallow excavation for installation is possible.

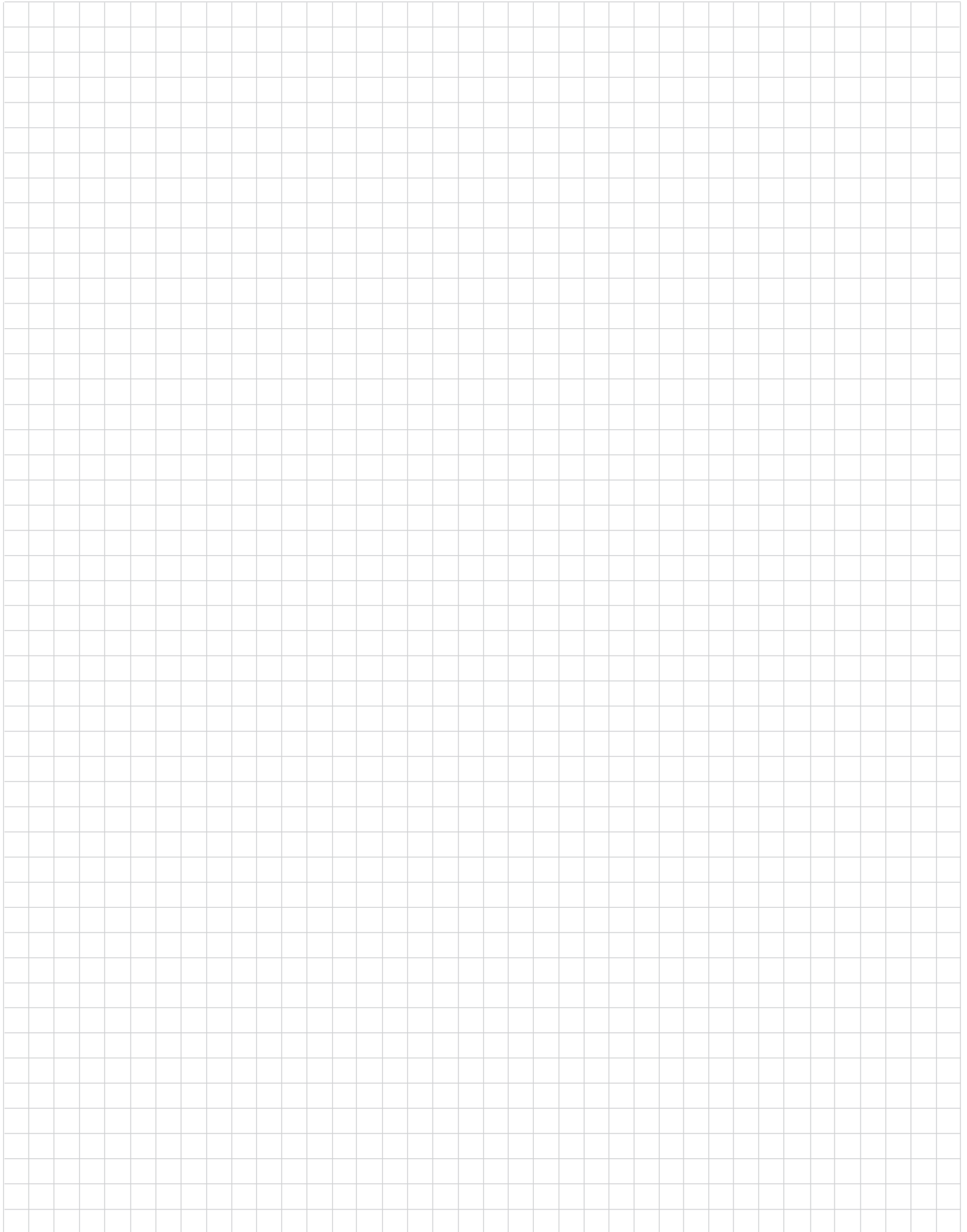

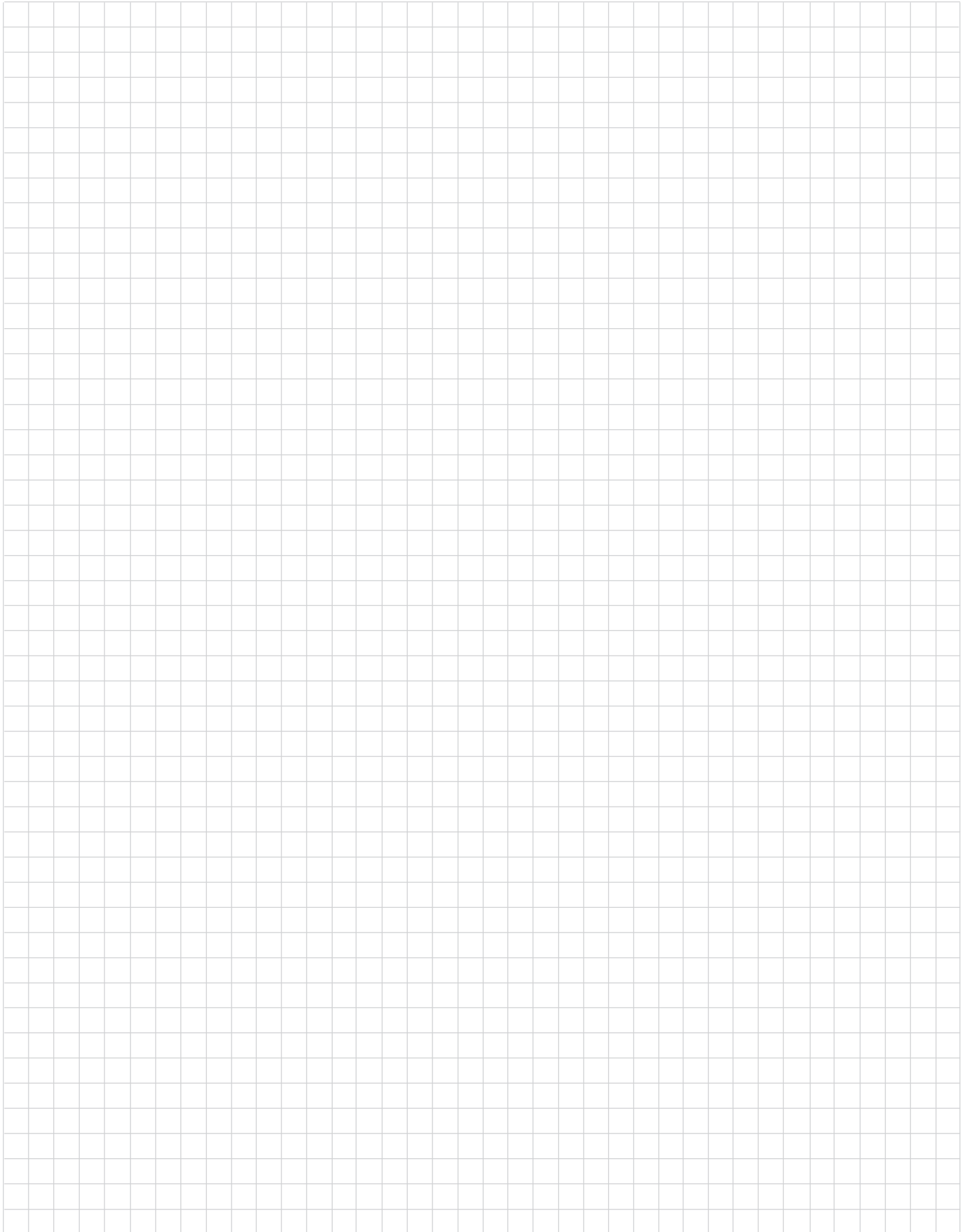

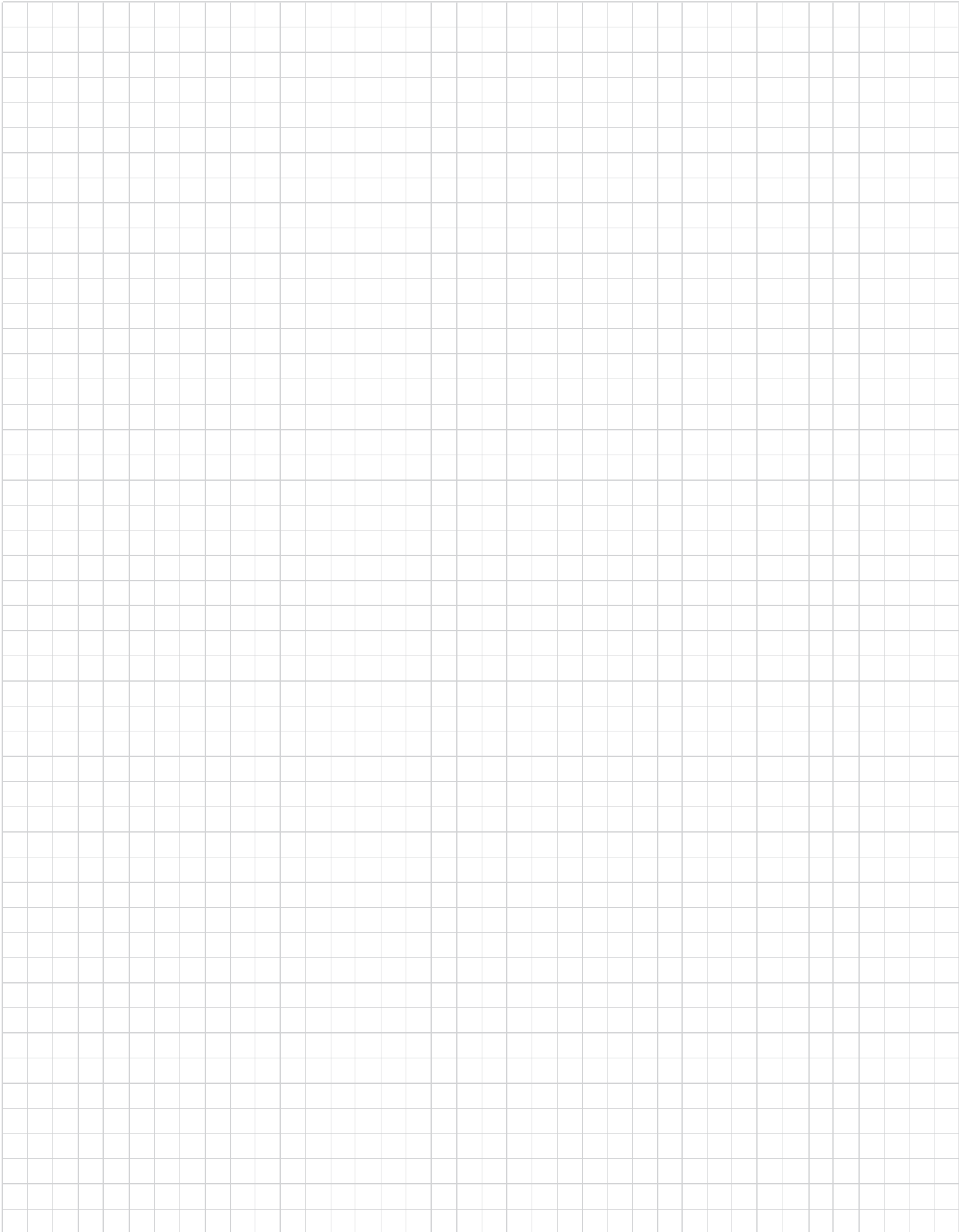

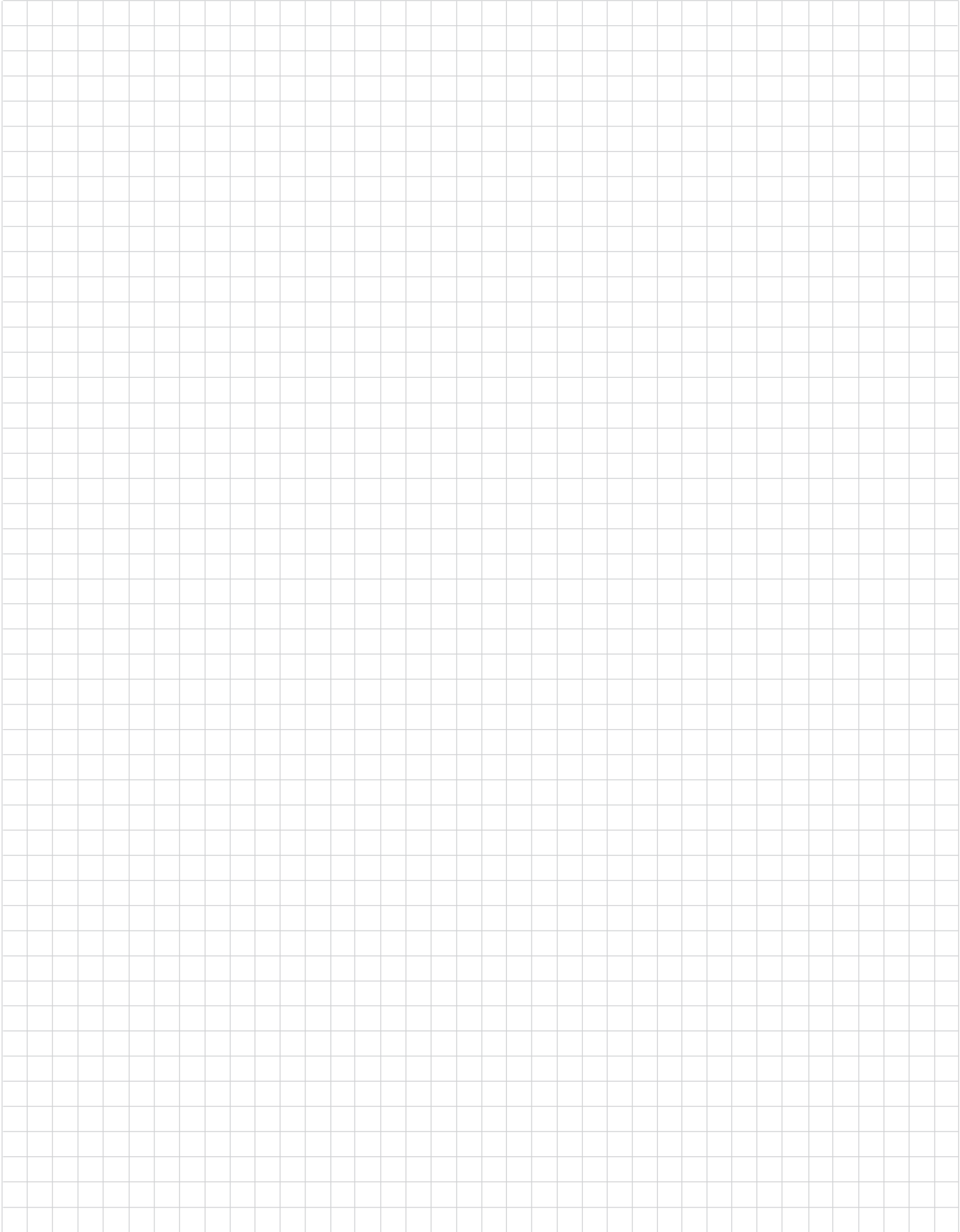

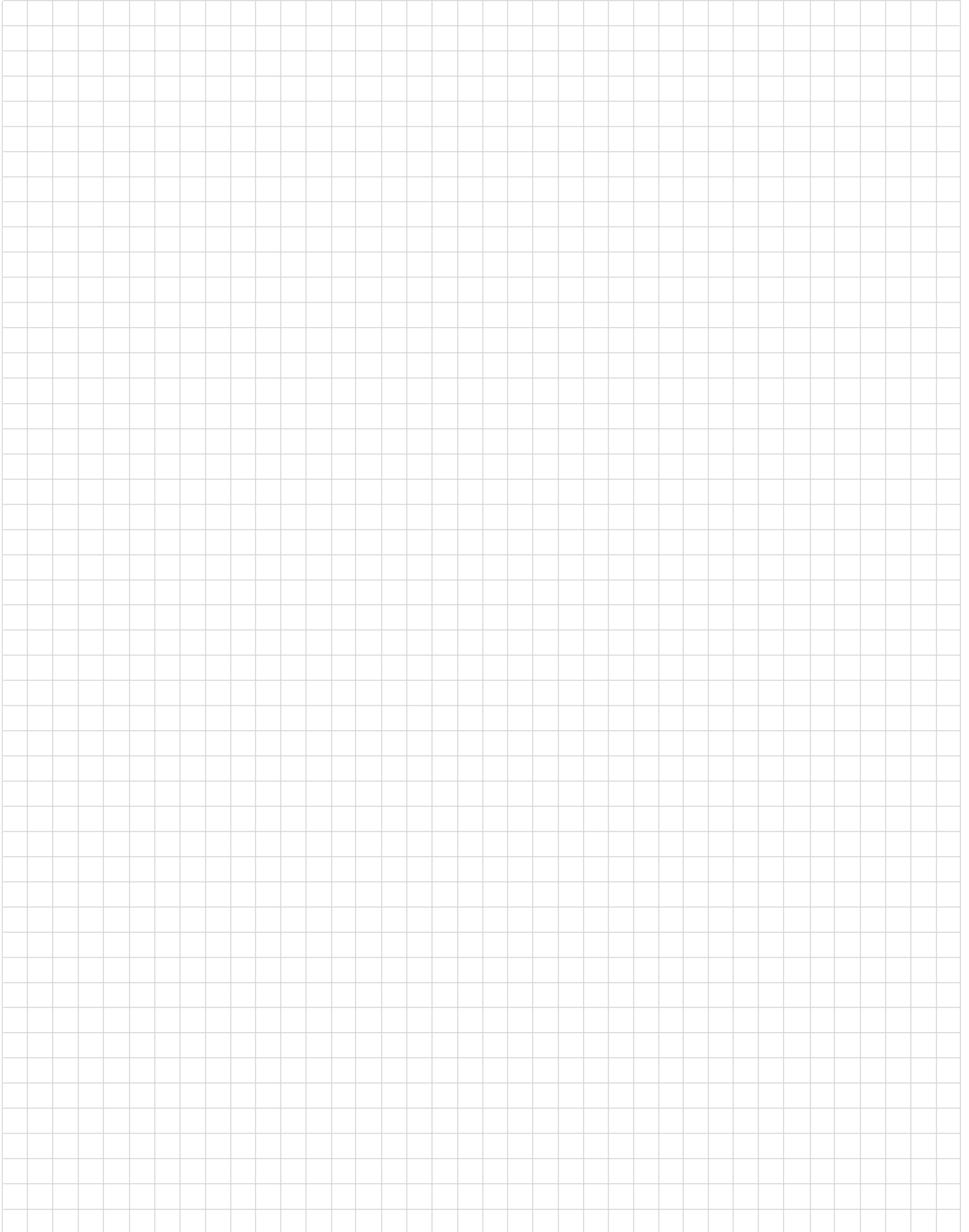



Althon Limited
MAG Group Building
Vulcan Road South, Norwich, NR6 6AF

Telephone : 01603 488700
Fax : 01603 488598
sales@althon.co.uk